



Каталог

По вопросам продаж и поддержки обращайтесь:

Архангельск (8182)63-90-72	Иваново (4932)77-34-06	Магнитогорск (3519)55-03-13	Пермь (342)205-81-47	Сургут (3462)77-98-35
Астана (7172)727-132	Ижевск (3412)26-03-58	Москва (495)268-04-70	Ростов-на-Дону (863)308-18-15	Тверь (4822)63-31-35
Астрахань (8512)99-46-04	Казань (843)206-01-48	Мурманск (8152)59-64-93	Рязань (4912)46-61-64	Томск (3822)98-41-53
Барнаул (3852)73-04-60	Калининград (4012)72-03-81	Набережные Челны(8552)20-53-41	Самара (846)206-03-16	Тула (4872)74-02-29
Белгород (4722)40-23-64	Калуга (4842)92-23-67	Нижний Новгород (831)429-08-12	Санкт-Петербург (812)309-46-40	Тюмень (3452)66-21-18
Брянск (4832)59-03-52	Кемерово (3842)65-04-62	Новокузнецк (3843)20-46-81	Саратов (845)249-38-78	Ульяновск (8422)24-23-59
Владивосток (423)249-28-31	Киров (8332)68-02-04	Новосибирск (383)227-86-73	Севастополь (8692)22-31-93	Уфа (347)229-48-12
Волгоград (844)278-03-48	Краснодар (861)203-40-90	Омск (3812)21-46-40	Симферополь (3652)67-13-56	Хабаровск (4212)92-98-04
Вологда (8172)26-41-59	Красноярск (391)204-63-61	Орел (4862)44-53-42	Смоленск (4812)29-41-54	Челябинск (351)202-03-61
Воронеж (473)204-51-73	Курск (4712)77-13-04	Оренбург (3532)37-68-04	Сочи (862)225-72-31	Череповец (8202)49-02-64
Екатеринбург (343)384-55-89	Липецк (4742)52-20-81	Пенза (8412)22-31-16	Ставрополь (8652)20-65-13	Ярославль (4852)69-52-93

CONTENTS

TEMPERATURE DEFROST, HUMIDITY, PRESSURE, TIME, MONITORING

LTR-5 Single output control	Page 4
ACI-5 Two channel control	Page 4
ACI-27 Two channel control	Page 5
ACI-2W Two channel control	Page 5
ATI-5 HT defrost control	Page 6
AT2-5 HT/LT defrost control	Page 6
AD2-5 Universal defrost control	Page 7
AR2-5 RTC defrost control	Page 7
AR2-27 RTC defrost control	Page 8
BIT25 OEM defrost control	Page 8
AD2-28 OEM defrost control	Page 9
AR2-28 OEM RTC defrost control	Page 9
AH1-5 Transport refrigeration	Page 10
TMRI5 timed control	Page 10
MS27 compressor pack control	Page 11
MTR6 Single output thermostat	Page 12
LLC1SE Liquid level control	Page 12
LT12 meter	Page 13
LTS12 meter	Page 13
TAB4.2 monitoring,logging software	Page 14
SWB wireless modules	Page 15
WBS-01 webserver	Page 16
SN2B NTC2K temperature probe	Page 17
SN4B NTC10K temperature probe	Page 17
ST1K PTC temperature probe	Page 17
ST1N PTC temperature probe	Page 17
HT2WAD humidity probe	Page 17
HT2WSE temperature & humidity probe	Page 17
ZOT programming device	Page 17
PGT35 pressure probe	Page 18
S-28-FB fixing bar	Page 18
Transformers	Page 18

LTR-5

77x35x77mm

SINGLE OUTPUT ON/OFF OR PID THERMOSTAT OR HUMIDISTAT

Runs on mains power supply ● PID with autotuning or ON/OFF control ● Output on relay (16A) or SSR piloting ● Input for PTC, NTC10K or 0÷1V ● 0.1 / 1°C or 1°F resolution ● Refrigerating (dehumidifying) or heating (humidifying) control mode selection ● Stand-by button on the front ● Load start limitation and safety function in the event of breakage of the sensor ● Quick setup through ZOT-LTR device ● Connection to LAE supervisory systems TAB.

APPLICATIONS:

Temperature: Control of small cold stores, refrigerated cabinets and tables, heating systems, heated cupboards, bain-marie, ovens, laboratory equipment.

Humidity: Control of greenhouses, seasoning cells, cold rooms, air-conditioned rooms.

LTR-5 Series

Functions	LTR-5T..	LTR-5C..	LTR-5A..
Input type	PTC	NTC10K	0÷1V
Range	-50÷150°C -60÷300°F	-40÷125°C -40÷260°F	0÷99.9% r.H.
Accuracy	±0.3°C ^(a) , ±1.0°C ^(c)	±0.3°C ^(b) , ±1°C ^(c)	±0.7% r.H.
Resolution	0.1/1°C; °F		0.1/1 % r.H.
Front protection	IP55		
Panel cut-out	71x29 mm		

(a) -50÷140°C; (b) -40÷110°C; (c) remaining range.

How to order examples:

LTR-5CSRE-A (NTC10K input, 1 relay, screw terminals, 230Vac supply, TTL port)
LTR-5ASRU (0÷1V input, 1 relay, screw terminals, 115Vac supply, no serial port)

On request, the LTR-5 is also available with gasket for a better protection between bezel and panel.

In order to know more options available for the models, please consult LAE or our local dealer.



LTR-5	T	S	R	E	-B
	1	2	3	4	5

POS.	FUNCTION	DESCRIPTION
1	Input	T = PTC; C = NTC10K; A = 0÷1V
2	Connectors	S = screw terminals; O = male+female terminals
3	Output type	R = relay; F = SSR drive
4	Supply	D = 12Vac/dc; E = 230Vac; U = 115Vac, 2W
5	Serial comm.	- = no serial port; -A = TTL; -B = RS485

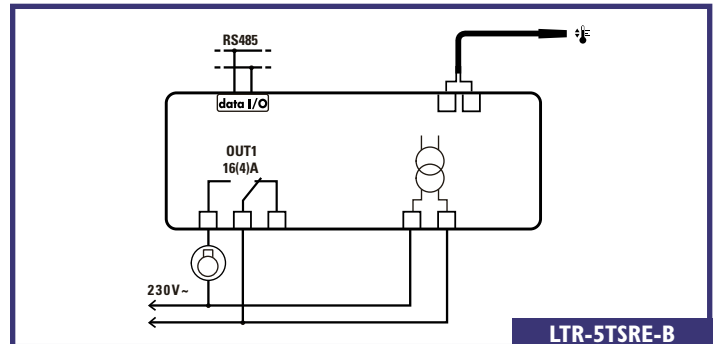

LTR-5TSTRE-B

ACI-5

77x35x77 mm

TWO CHANNEL UNIVERSAL CONTROLLER, ON/OFF OR PID

Runs on mains power supply ● PID with autotuning or ON/OFF control ● Main output on 12A relay or for SSR-piloting and auxiliary output on 5A relay ● Input for 0÷1V, 0/4÷20mA, PTC/NTC10K, TC J/K or Pt100 ● 0.1 / 1°C or 1°F resolution ● Selectable Refrigerating/Heating (Dehumidifying/Humidifying) control ● Absolute and relative temperature alarms ● ON/OFF button on front ● Load start limitation and safety operation in case of probe failure ● Quick programming through ZOT-ACI key ● Connection to LAE TAB supervisory systems

APPLICATIONS:

Temperature: Control of small cold stores, refrigerated cabinets and tables, heating systems, heated cupboards, bain-marie, ovens, laboratory equipment.

Humidity: Control of greenhouses, seasoning cells, cold rooms, air-conditioned rooms.

ACI-5 Series

Functions	ACI-5T..	ACI-5P..	ACI-5J..	ACI-5A..	ACI-5I..
Input type	PTC	NTC10K	Pt100	TC "J" TC "K"	0÷1V 0/4÷20mA
Range	-50÷150°C -60÷300°F	-40÷125°C -40÷260°F	-100÷850°C -150÷999°F	-50÷750°C -60÷999°F	-50÷999°C -60÷999°F
Accuracy	±0.3°C	±0.3°C	±0.3°C ^(a) , ±1°C ^(b)	±3°C	±3mV ±0.2mA
Resolution	0.1 / 1 °C / 1 °F		1 °C / °F		0.1/1

(a) -50÷150°C; (b) remaining range.

How to order:

ACI-5TS2RW-A (PTC/NTC10K input, screw terminals, 2 relays, 115÷230Vac supply voltage, TTL port)
ACI-5AS2MD-B (0÷1V input, screw terminals, output 1 on SSR drive, output 2 on relay, 12Vac/dc supply voltage, RS485 port)

On request, the ACI-5 is also available with gasket for a better protection between bezel and panel.

In order to know versions available, please consult LAE or our local dealer.



ACI-5	T	S	1	R	W	-B
	1	2	3	4	5	6

POS.	FUNCTION	DESCRIPTION
1	Input	A = 0÷1V; I = 0/4÷20mA; J = TC 'J' / 'K'; P = Pt100; T = PTC/ NTC10K
2	Connections	S = built-in screw terminals
3	Output No.	1 = one; 2 = two
4	Output type	R = relay; M = Out1 on SSR, Out2 on relay
5	Supply	D* = 12Vac/dc; W = 115...230Vac 50/60Hz; 3 W
6	Serial comm.	Nil = no; -A = TTL; -B = RS485

* = in the version with 12Vac/dc power supply, the maximum voltage on the outputs is 50Vac/dc, in order to ensure safety insulations.

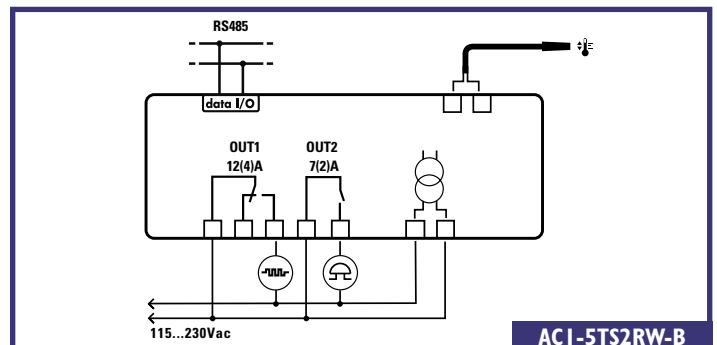

ACI-5TS2RW-B



71x97x61mm DIN RAIL

AC1-27

TWO CHANNEL UNIVERSAL CONTROLLER, ON/OFF OR PID

Runs on mains power supply ● PID with autotuning or ON/OFF control ● Main output on 12A relay or for SSR-piloting and auxiliary output on 5A relay ● Input for 0÷1V, 0/4÷20mA, PTC/NTC10K, TC J/K or Pt100 ● 0.1 / 1°C or 1°F resolution ● Selectable Refrigerating/Heating (Dehumidifying/Humidifying) control ● Absolute or relative temperature alarms ● ON/OFF button on front ● Load start limitation and safety operation in case of probe failure ● Quick programming through ZOT-ACI key ● Connection to LAE TAB supervisory systems

AC1-27	T	S	1	R	E	-B
	1	2	3	4	5	6

POS.	FUNCTION	DESCRIPTION
1	Input	A = 0÷1V; I = 0/4÷20mA; J = TC 'J' / 'K'; P = Pt100; T = PTC/ NTC10K
2	Connections	S = built-in screw terminals
3	Output No.	1 = one; 2 = two
4	Output type	R = relay; M = Out1 on SSR, Out2 on relay
5	Supply	D = 12Vac/dc; E = 230Vac 50/60Hz; U = 115Vac 50/60Hz 3 W
6	Serial comm.	Nil = no; -A = TTL; -B = RS485

APPLICATIONS:

Temperature: on control panels for small cold stores, heating systems, heated cupboards, bains-marie, ovens, laboratory equipment.

Humidity: control panels for greenhouses, seasoning cells, cold rooms, air-conditioned rooms.

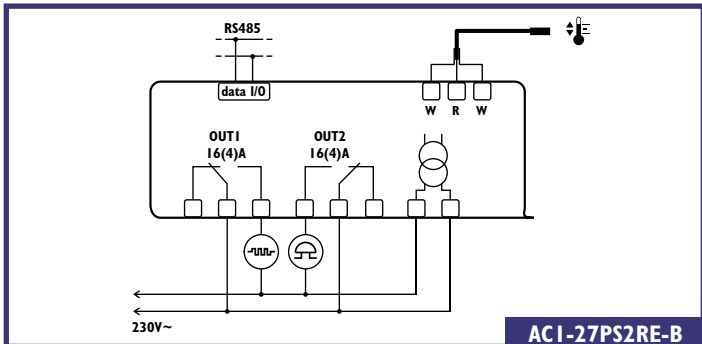

AC1-27 Series

Functions	AC1-27T..	AC1-27P..	AC1-27J..	AC1-27A..	AC1-27I..
Input type	PTC	NTC10K	Pt100	TC "J"	TC "K"
Range	-50÷150°C -60÷300°F	-40÷125°C -40÷260°F	-100÷850°C -150÷999°F	-50÷750°C -60÷999°F	-50÷999°C -60÷999°F
Accuracy	±0.3°C	±0.3°C	±0.3°C ^(a) ±1°C ^(b)	±3°C	±3mV
Resolution	0.1 / 1 °C / 1 °F		1 °C / °F	0.1/1	

(a) -50÷150°C; (b) remaining range.

How to order:

AC1-27S1RE-B (TC J/K input, screw terminals, 1 relay output, 230Vac supply voltage, RS485 port).
AC1-27S2MD-A (0/4÷20mA input, screw terminals, output 1 on SSR drive, output 2 on relay, 12Vac/dc supply voltage, TTL port)

In order to know versions available, please consult LAE or our local dealer.



110x53x75mm

AC1-2W

TWO CHANNEL UNIVERSAL CONTROLLER, ON/OFF OR PID

Wall-mount controller ● Runs on mains power supply ● PID with autotuning or ON/OFF control ● Outputs on relay or for SSR-piloting ● Input for 0÷1V, PTC/NTC10K ● 0.1 / 1°C or 1°F resolution ● Selectable Refrigerating/Heating (Dehumidifying/Humidifying) control ● Absolute or relative temperature alarms ● ON/OFF button on front ● Load start limitation and safety operation in case of probe failure ● Quick programming through ZOT-ACI key ● Connection to LAE TAB supervisory systems

AC1-2W	T	Q	1	R	E	-B
	1	2	3	4	5	6

POS.	FUNCTION	DESCRIPTION
1	Input	A = 0÷1V; T = PTC/ NTC10K
2	Connections	Q = detachable screw terminals
3	Output No.	1 = one; 2 = two
4	Output type	R = relay; F = SSR drives
5	Supply	D = 12Vac/dc; E = 230Vac 50/60Hz; U = 115Vac 50/60Hz 3 W
6	Serial comm.	Nil = no; -A = TTL; -B = RS485

APPLICATIONS:

Temperature: control of small cold stores, swimming pools, heating systems, laboratory equipment.

Humidity: control of greenhouses, seasoning cells, cold rooms, air-conditioned rooms.

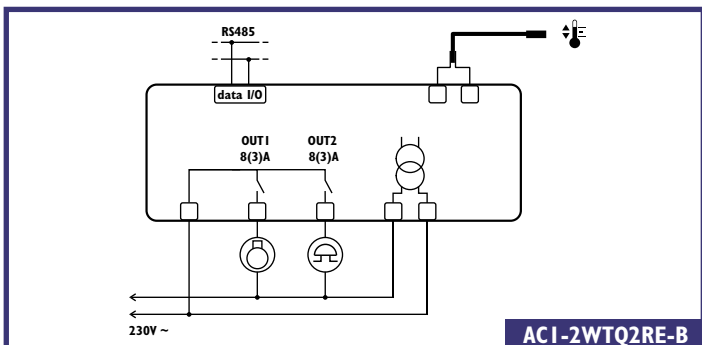

AC1-2W Series

Functions	AC1-2WT..	AC1-2WA..
Input type	PTC	NTC10K
Range	-50÷150°C -60÷300°F	-40÷125°C -40÷260°F
Accuracy	±0.3°C	±0.3°C
Resolution	0.1 / 1 °C / 1 °F	

How to order:

AC1-2WTQ2RE-B (PTC/NTC10K input, detachable screw terminals, 2 relays, 230Vac supply voltage, RS485 port)
AC1-2WAQ2RD-A (0÷1V input, detachable screw terminals, 2 relays, 12Vac/dc supply voltage, TTL port)

In order to know versions available, please consult LAE or our local dealer.

AT1-5

77x35x77 mm

UNIVERSAL DEFROST CONTROLLER FOR HIGH TEMPERATURE

Selectable Refrigerating or Heating control • Runs on mains power supply • Direct compressor control through high power 16(4)A, 16(5)A or 16(8)A relay • Selectable NTC10K or PTC probe input • Integrated defrost functions • Auxiliary output configurable in four different operation modes • Absolute or relative temperature alarms • Door open alarm • Automatic condenser maintenance warning • On/Off button • Optional light control button • Quick programming through ZOT-AT1 key • Connection to LAE supervisory systems

APPLICATIONS:

Freestanding upright cabinets and counters, cold stores, plug-in display cases, control panels, heated cabinets.

AT1-5 Series

Functions	AS1E-G	BS2E-BG	BS6E-AL
Inputs			
thermostat	✓	✓	✓
evaporator		✓	✓
door switch		✓	✓
Outputs			
thermostat 16(4)A	✓	✓	✓
thermostat 16(8)A			✓
auxiliary 7(2)A		✓	✓
Power supply			
230Vac	✓	✓	✓
Serial port			
TTL			✓
RS485		✓	✓
Keypad			
generic	✓	✓	✓
with light button			✓

Models with removable screw terminal blocks are available. In this case, the letter "S" of code changes in "Q", ex. AT1-5BQ2E-BG.

All models come with an alarm buzzer. Versions with 110V power supply are available.

On request, the AT1-5 is also available with gasket for a better protection between bezel and metal panel.

In order to know more options available for the models, please consult LAE or our local dealer.



TECHNICAL DATA

Control Range:		-50÷120°C, -55÷240°F
Resolution:		0.1/1 °C; °F
Accuracy:	NTC10K:	<±0.3°C (-40.0÷70.0°C)
	PTC1000:	<±0.5°C (-50÷120°C)
Sensor type:		selectable NTC10K or PTC1000
Power supply:		230V~ ±10% 50÷60Hz 3W
Front protection:		IP55
Panel cut-out:		71x29 mm

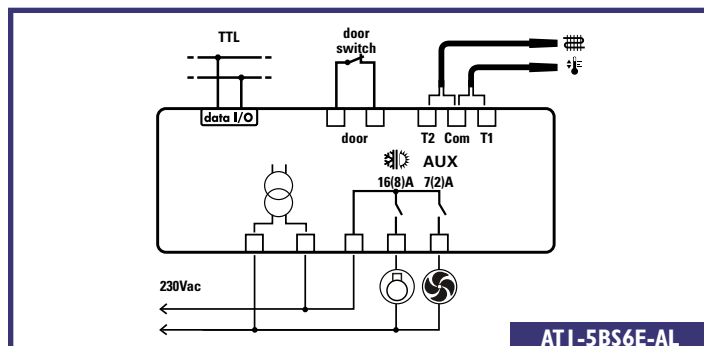

AT1-5BS6E-AL

AT2-5

77x35x77 mm

UNIVERSAL DEFROST CONTROLLER FOR HIGH AND LOW TEMPERATURE

Selectable Refrigerating or Heating control • Runs on mains power supply • Direct compressor control through high power 16(5)A • Excellent evaporator fan control • Auxiliary output configurable in six different operating modes • Selectable NTC10K or PTC input • Electrical, off cycle or hot gas defrost • Absolute or relative temperature alarms • Door open alarm • Automatic condenser maintenance warning • On/Off button • Optional light control button • Quick programming through ZOT-AT2 key

APPLICATIONS:

High or Low Temperature upright cabinets and counters, cold stores, plug-in display cases, control panels, heated cabinets.

AT2-5 Series

Functions	BS4E-G	BS4E-AG	BS4E-AL
Inputs			
thermostat	✓	✓	✓
evaporator	✓	✓	✓
door switch	✓	✓	✓
Outputs			
thermostat	✓	✓	✓
evaporator fans	✓	✓	✓
auxiliary	✓	✓	✓
Power supply			
230Vac	✓	✓	✓
Serial port			
serial port TTL		✓	✓
Keypad			
generic	✓	✓	✓
with light button			✓

Models with removable screw terminal blocks are available. In this case, the letter "S" of code changes in "Q", ex. AT2-5BQ4E-AL.

All models come with an alarm buzzer. Versions with 110V power supply are available.

Upon request, against large batches, the AT2-5 is also available with RS485 serial port

On request, the AT2-5 is also available with gasket for a better protection between bezel and metal panel.

In order to know more options available for the models, please consult LAE or our local dealer.



TECHNICAL DATA

Control Range:		-50÷120°C, -55÷240°F
Resolution:		0.1/1 °C; °F
Accuracy:	NTC10K:	<±0.3°C (-40.0÷70.0°C)
	PTC1000:	<±0.5°C (-50÷120°C)
Sensor type:		selectable NTC10K or PTC1000
Power supply:		230V~ ±10% 50÷60Hz 3W
Front protection:		IP55
Panel cut-out:		71x29 mm

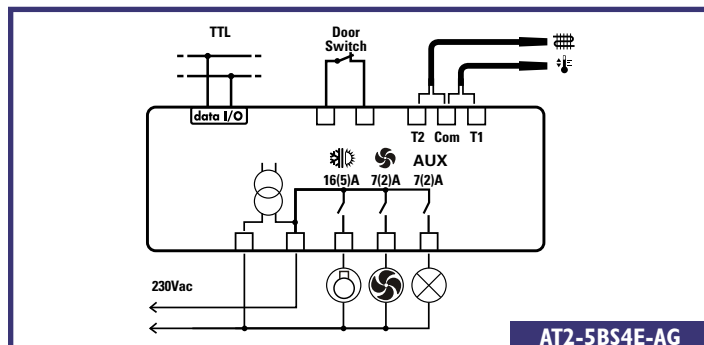

AT2-5BS4E-AG



77x35x90 MM

AD2-5

DEFROST CONTROLLER FOR DISPLAY CASES AND COLD STORES

Cyclic defrosts ● Synchronized defrost start and termination with master-slave connection ● Selectable NTC10K or PTC input ● FLEXICOLD function for energy saving or alternative setpoint ● Direct compressor control through high power 12(5)A relay ● Optional control of a second compressor or evaporator ● Excellent evaporator fan control ● Absolute or relative temperature alarms, door open alarm, condenser high temperature/pressure alarm ● Light and standby control (On/Off) ● Quick programming through ZOT-AD2 ● Connection to LAE supervisory systems

TECHNICAL DATA

Control Range:	-50÷120°C, -55÷240°F	
Resolution:	0.1 / 1 °C; °F	
Accuracy:	NTC10K:	<±0.3°C (-40.0÷70.0°C)
	PTC1000:	<±0.5°C (-50÷120°C)
Sensor type:	selectable NTC10K or PTC1000	
Power supply:	115÷230V~ ±10% 50÷60Hz 3W	
Front protection:	IP55	
Panel cut-out:	71x29 mm	

APPLICATIONS:

Plug-in cabinets, supermarket display cases, cold stores, control panels, upright fridges and freezers, refrigerated tables.

AD2-5 Series

Functions		B14D-AL	B23W-AG	C34W-BG
Temperature Inputs	thermostat	✓	✓	✓
	evaporator	✓	✓	✓
	auxiliary	✓	✓	✓
Door switch input	Voltage free contact	✓	✓	✓
	Voltage free contact	✓		
Digital inputs	12÷24Vac voltage		✓	
	Defrost synchronisation			✓
Outputs	thermostat	✓	✓	✓
	evaporator fans	✓	✓	✓
	defrost	✓	✓	✓
	auxiliary	✓	✓	✓
Power supply	115-230Vac	✓	✓	✓
	12Vac/dc	✓		
Serial port	TTL serial port	✓	✓	
	RS485 serial port			✓
Keypad	generic		✓	✓
	with light button	✓		

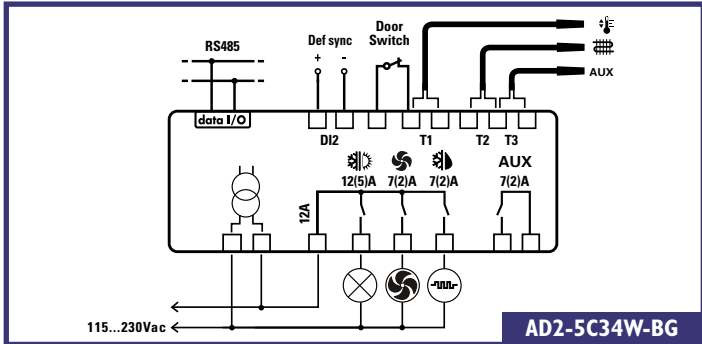

All models come with an alarm buzzer. All models are fitted with detachable screw terminals. On request, the AD2-5 is also available with gasket for a better protection between bezel and metal panel. In order to know more options available for the models, please consult LAE or our local dealer.



77x35x90 MM

AR2-5

DEFROST CONTROLLER WITH RTC FOR DISPLAY CASES AND COLD STORES

Up to 6 real time defrosts ● Synchronized defrost start and termination with master-slave connection ● Selectable NTC10K or PTC input ● FLEXICOLD function for energy saving or alternative setpoint ● Direct compressor control through high power 12(5)A relay ● Optional control of a second compressor or evaporator ● Excellent evaporator fan control ● Absolute or relative temperature alarms, door open alarm, condenser high temperature/pressure alarm ● Light and standby control (On/Off) ● Quick programming through ZOT-AR2 ● Connection to LAE supervisory systems

TECHNICAL DATA

Control Range:	-50÷120°C, -55÷240°F	
Resolution:	0.1 / 1 °C; °F	
Accuracy:	NTC10K:	<±0.3°C (-40.0÷70.0°C)
	PTC1000:	<±0.5°C (-50÷120°C)
Sensor type:	selectable NTC10K or PTC1000	
Power supply:	115÷230V~ ±10% 50÷60Hz 3W	
Rechargeable battery:	>150 hours	
Front protection:	IP55	
Panel cut-out:	71x29 mm	

APPLICATIONS:

Plug-in cabinets, supermarket display cases, cold stores, control panels, upright fridges and freezers, refrigerated tables and all those plants where real time defrost starts are needed.

AR2-5 Series

Functions		B14D-AL	B23W-AG	C34W-BG
Temperature Inputs	Thermostat	✓	✓	✓
	Evaporator	✓	✓	✓
	Auxiliary	✓	✓	✓
Door switch input	Voltage free contact	✓	✓	✓
	Voltage free contact	✓		
Digital inputs	12÷24Vac voltage		✓	
	Defrost synchronisation			✓
Outputs	Thermostat	✓	✓	✓
	Evaporator fans	✓	✓	✓
	Defrost	✓	✓	✓
	Auxiliary	✓	✓	✓
Power supply	115-230Vac	✓	✓	✓
	12Vac/dc	✓		
Serial port	Serial port TTL	✓	✓	
	Serial port RS485			✓
Keypad	Generic		✓	✓
	With light button	✓		

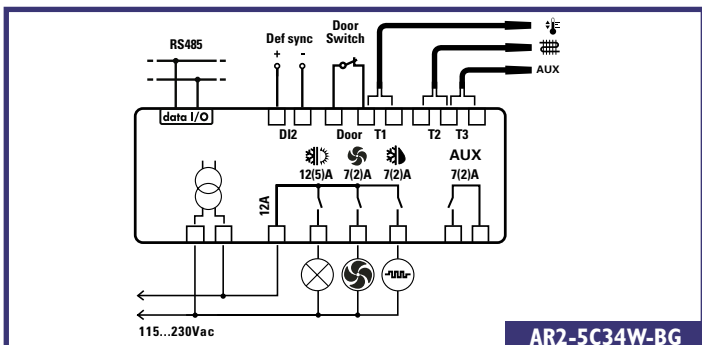

All models come with an alarm buzzer. All models are fitted with detachable screw terminals. On request, the AR2-5 is also available with gasket for a better protection between bezel and metal panel. In order to know more options available for the models, please consult LAE or our local dealer.

AR2-27

71x97x61 mm DIN RAIL

UNIVERSAL DEFROST CONTROLLER WITH RTC

Selectable Refrigerating or Heating control • Selectable NTC10K or PTC input • FLEXICOLD function for energy saving or alternative setpoint • Cyclic defrosts or scheduled real time starts • Synchronized defrost start and termination with master-slave connection • Optional control of a second compressor or evaporator • Excellent evaporator fan control • Absolute or relative temperature alarms and door open alarm • Temperature and pressure monitoring and condensing unit maintenance • Light and standby control (On/Off) • Quick programming through ZOT-AR2 • Connection to LAE supervisory systems

APPLICATIONS:

On control panels for cold stores, plug-in and supermarket display cases.

AR2-27 Series

Functions	B13E-AG	C24E-AG	C35E-BG
Temperature Inputs			
Thermostat	✓	✓	✓
Evaporator	✓	✓	✓
Auxiliary	✓	✓	✓
Door switch input			
Voltage free contact	✓	✓	✓
Digital inputs			
Voltage free contact	✓		
12÷24Vac voltage		✓	
Defrost synchronisation			✓
Outputs			
Thermostat	✓	✓	✓
Evaporator fans	✓	✓	✓
Defrost	✓	✓	✓
Auxiliary 1	✓	✓	✓
Auxiliary 2	✓	✓	✓
Power supply			
230Vac	✓	✓	✓
Serial port			
Serial port TTL	✓	✓	✓
Serial port RS485			✓
Keypad			
Generic	✓	✓	✓

All models come with an alarm buzzer.

Versions with power supply 12Vac/dc and 115Vac are also available.

In order to know more options available for the models, please consult LAE or our local dealer.



TECHNICAL DATA

Control Range:	-50÷120°C, -55...240°F
Resolution:	0.1/1 °C; °F
Accuracy:	NTC10K: $\leq \pm 0.3^\circ\text{C}$ (-40.0÷70.0°C) PTC1000: $\leq \pm 0.5^\circ\text{C}$ (-50÷120°C)
Sensor type:	selectable NTC10K or PTC1000
Power supply:	230Vac $\pm 10\%$ 50÷60Hz 3W
Rechargeable battery:	>150 hours
Front protection:	IP55

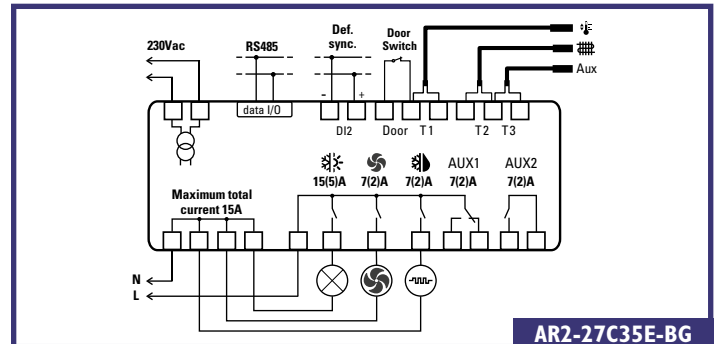

AR2-27C35E-BG

BIT-25

86x82x44 mm

SPLIT DEFROST CONTROLLER

Three highly rated relay outputs • Configurable control of Aux 1 and Aux 2 outputs • Alternate set of parameters for energy saving • Management of multiple alarms • Option of setpoint adjustment via a potentiometer • Standby button (On/Off) • Option of universal power supply • Connection to LAE supervisory systems

APPLICATIONS:

Upright refrigerators, bottle coolers, plug-in display cases for shops and supermarkets, cold stores, control panels.



TECHNICAL DATA: LCD-55 DISPLAY UNIT

Dimensions:	77x35x20 mm (WxHxD)	Panel cut-out: 71x29mm
Front protection:	IP55	

TECHNICAL DATA

Control Range:	-50...110°C, -58...180°F
Resolution:	0.1/1 °C; °F
Precision:	$\leq \pm 0.5^\circ\text{C}$ within the measurement range
Sensor type:	NTC10K
Power supply:	115Vac, 230Vac or universal 115.230Vac $\pm 10\%$ 50÷60Hz 3W

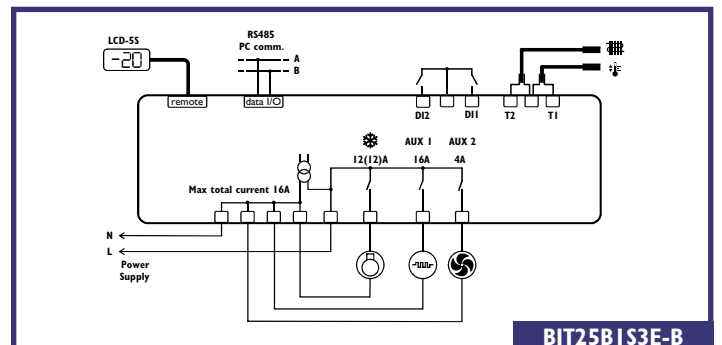

BIT25BIS3E-B

BIT25 Series

Functions	A0S2E-A	B1S3E-B
Temperature Inputs		
Thermostat	✓	✓
Evaporator	✓	✓
Digital inputs		
DI1 digital input	✓	✓
DI2 digital input	✓	✓
Outputs		
Thermostat	✓	✓
Auxiliary 1	✓	✓
Auxiliary 2	✓	✓
Power supply		
230Vac	✓	✓
Serial port		
TTL	✓	✓
RS485		✓

All models come with an alarm buzzer

In order to know more options available for the models, please consult LAE or our local dealer.



107x95x47 mm DIN RAIL

AD2-28

VERSATILE SPLIT DEFROST CONTROLLER

Cyclic defrosts ● Synchronized defrost start and termination with master-slave connection ● Selectable NTC10K or PTC input ● FLEXICOLD function for energy saving or alternative setpoint ● Optional control of a second compressor or evaporator ● Excellent evaporator fan control ● Absolute or relative temperature alarms, door open alarm, condenser high temperature/pressure alarm ● Light and standby control (On/Off) ● Quick programming through ZOT-AD2 ● Connection to LAE supervisory systems ● Available display unit: LCD-55 or RU33

APPLICATIONS:

Upright refrigerators, plug-in and supermarket display cases, cold stores, control panels.

TECHNICAL DATA: LCD-55 DISPLAY UNIT

Dimensions : 77x35x20 mm (WxHxD) Panel cut-out: 71x29mm
 Front protection: IP55

TECHNICAL DATA

Range: $-50 \div 120^{\circ}\text{C}$, $-55 \dots 240^{\circ}\text{F}$
 Resolution: 0.1 / 1 $^{\circ}\text{C}$, $^{\circ}\text{F}$
 Precision: NTC10K: $< \pm 0.3^{\circ}\text{C}$ ($-40.0 \div 70.0^{\circ}\text{C}$)
 PTC1000: $< \pm 0.5^{\circ}\text{C}$ ($-50 \div 120^{\circ}\text{C}$)
 Sensor type: selectable NTC10K or PTC1000
 Power supply: 230Vac $\pm 10\%$ 50=60Hz 3W

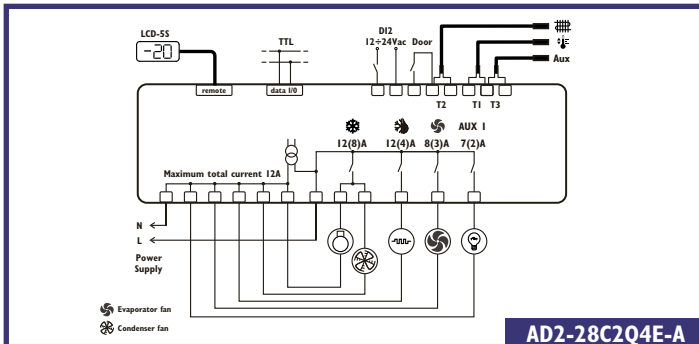

AD2-28C2Q4E-A

AD2-28 series

Functions	B1S3E-A	C2Q4E-A	C3R5U-B
Temperature inputs	Thermostat	✓	✓
	Evaporator	✓	✓
	Auxiliary	✓	✓
Door switch input	Voltage free contact	✓	✓
	Voltage free contact	✓	✓
DI2 aux. digital input	Voltage 12÷24Vac	✓	✓
	Defrost synchronisation		✓
	Connections	Quick with M/F connectors	✓
Display unit	Screw terminals	✓	✓
	LCD-55	✓	✓
Outputs	RU33		✓
	Thermostat	✓	✓
Power supply	Evaporator fans	✓	✓
	Defrost	✓	✓
	Auxiliary 1	✓	✓
	Auxiliary 2	✓	✓
	230Vac	✓	✓
Serial port	115Vac		✓
	TTL	✓	✓
	RS485	✓	✓

All models come with an alarm buzzer. Versions with power supply 12Vac are also available.

In order to know more options available for the models, please consult LAE or our local dealer.



107x95x47 mm

AR2-28

VERSATILE SPLIT DEFROST CONTROLLER WITH RTC

Up to 6 real time defrosts ● Synchronized defrost start and termination with master-slave connection ● Selectable NTC10K or PTC input ● FLEXICOLD function for energy saving or alternative setpoint ● Optional control of a second compressor or evaporator ● Excellent evaporator fan control ● Absolute or relative temperature alarms, door open alarm, condenser high temperature/pressure alarm ● Light and standby control (On/Off) ● Quick programming through ZOT-AR2 ● Connection to LAE supervisory systems ● Available display unit: LCD-55 or RU33

APPLICATIONS

Cold stores, control panels, upright refrigerators, plug-in and supermarket display cases, and all those plants where real time defrost starts are needed.

TECHNICAL DATA: RU33 DISPLAY UNIT

Dimensions: 169x38x25 mm (WxHxD) Panel cut-out: 163x31.5 mm
 Front protection: IP55

TECHNICAL DATA

Range: $-50 \dots 120^{\circ}\text{C}$, $-55 \dots 240^{\circ}\text{F}$
 Resolution: 0.1 / 1 $^{\circ}\text{C}$, $^{\circ}\text{F}$
 Precision: NTC10K: $< \pm 0.3^{\circ}\text{C}$ ($-40.0 \div 70.0^{\circ}\text{C}$)
 PTC1000: $< \pm 0.5^{\circ}\text{C}$ ($-50 \div 120^{\circ}\text{C}$)
 Sensor type: selectable NTC10K or PTC1000
 Rechargeable battery: >150 hours
 Power supply: 230V~ $\pm 10\%$ 50=60Hz 3W

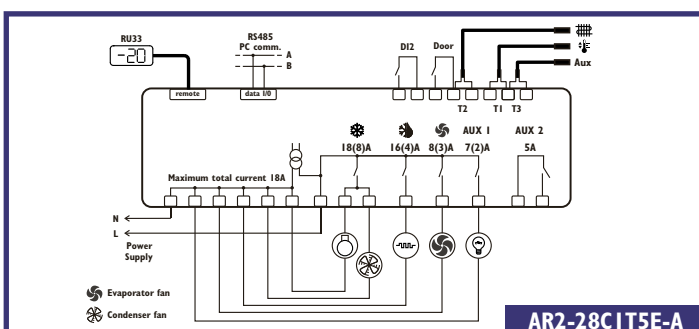

AR2-28C1T5E-A

AR2-28 series

Functions	B1S3E-B	C2Q4E-B	C3R5U-A
Temperature inputs	Thermostat	✓	✓
	Evaporator	✓	✓
	Auxiliary	✓	✓
Door switch input	Voltage free contact	✓	✓
	Voltage free contact	✓	✓
DI2 aux. digital input	12÷24Vac voltage	✓	✓
	Defrost synchronisation		✓
Connections	Quick with M/F connectors	✓	✓
	Screw terminals	✓	✓
Display unit	LCD-55	✓	✓
	RU33		✓
Power supply	Thermostat	✓	✓
	Evaporator fans	✓	✓
	Defrost	✓	✓
	Auxiliary 1	✓	✓
	Auxiliary 2	✓	✓
Serial port	230Vac	✓	✓
	115Vac		✓
	TTL	✓	✓
	RS485	✓	✓

All models come with an alarm buzzer. Versions with power supply 12Vac are also available.

In order to know more options available for the models, please consult LAE or our local dealer.

AH1-5

77x35x90 mm

DEFROST CONTROLLER FOR REFRIGERATED TRANSPORTS

Selectable Heating/Refrigerating control with Neutral Band ● Selectable NTC10K or PTC input ● FLEXICOLD function for energy saving or alternative setpoint ● Timed or optimised defrost start, or remote start option ● Defrost timer backup in case of power failure ● Direct compressor control through high power relay ● Optional control of a second compressor or evaporator ● Excellent evaporator fan control ● Absolute or relative temperature alarms and door open alarm ● Temperature and pressure monitoring and condensing unit maintenance ● Light and standby control (On/Off) ● Quick programming through ZOT-AH1 key ● Connection to LAE supervisory systems

APPLICATIONS:

refrigerated transports, HT and LT cold storage rooms, plug-in cabinets, display cases, open counters.

AH1-5 series

Functions		B14L-AG	B13W-AG	C24W-BL
Temperature inputs	Thermostat	✓	✓	✓
	Evaporator	✓	✓	✓
	Auxiliary			✓
Door switch input	Voltage free contact	✓	✓	✓
	Voltage 12÷24Vac	✓	✓	
Outputs	Thermostat	✓	✓	✓
	Evaporator fans	✓	✓	✓
	Defrost	✓	✓	✓
Power supply	115-230Vac		✓	✓
	7-30Vdc	✓		
Serial port	TTL	✓	✓	
	RS485			✓
Keypad	Generic	✓	✓	
	With light button			✓

All models come with an alarm buzzer. All models are fitted with detachable screw terminals. On request, the AH1-5 is also available with gasket for a better protection between bezel and metal panel. In order to know more options available for the models, please consult LAE or our local dealer.



TECHNICAL DATA

Control Range:	-50÷120°C, -55÷240°F
Resolution:	0.1/1 °C; °F
Accuracy:	NTC10K: $\leq \pm 0.3^\circ\text{C}$ (-40.0÷70.0°C)
	PTC1000: $\leq \pm 0.5^\circ\text{C}$ (-50÷120°C)
Sensor type:	selectable NTC10K or PTC1000
Power supply:	115-230V~ ±10% 50÷60Hz 3W
Front protection:	IP55
Panel cut-out:	71x29 mm

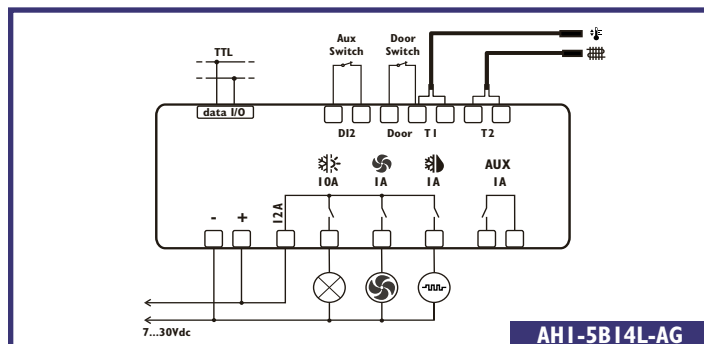

TMR15

77x35x77 mm

COUNTDOWN TIMER

Panel timer ● Countdown in hours and minutes or minutes and seconds ● Manual start/stop of countdown ● Remote start of countdown ● Manual switching on/off of output ● Mains powered ● Buzzer to warn countdown end ● Keypad lock option.

APPLICATIONS:

Control of duration of industrial processes, control of dough retarders, control of cooking time in ovens.



TECHNICAL DATA

Outputs:	Out 1 6(4)A 240V~
Power supply:	230Vac ±10% 3W
Front protection:	IP55
Panel cut-out :	71x29 mm

Standard versions	Power supply	Buzzer
TMR15E	230Vac ±10%, 3W	
TMR15E-A	230Vac ±10%, 3W	✓
TMR15D-A	12Vac/dc ±10%, 3W	✓

Versions with 110V supply are also available.

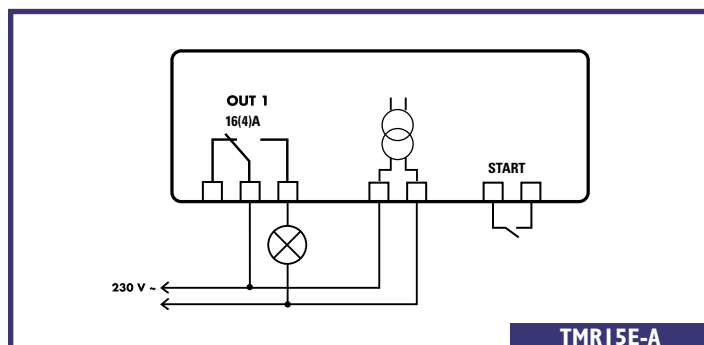



71x97x61 mm DIN RAIL

MS-27

MULTI-COMPRESSOR OR MULTI-FAN CONTROLLER

Four ON/OFF outputs for the control of single or multi-stage compressors or fans. ● Proportional output for speed control (inverters). ● Output with change-over contacts for alarm control. ● Input for pressure transmitter (0/4...20mA) or for a temperature probe (NTC10K). ● Two digital inputs on voltage free contact for programmable function, up to three digital optocoupled voltage inputs for a complete system diagnostics. ● Selection of the control algorithm: rotation of outputs, sequential activation, optimisation of the available power. ● Pressure – Temperature conversion according to gas used. ● Storage of the latest nine alarms ● Automatic maintenance management. ● 115Vac or 230Vac power supply by means of built-in transformer. ● Connections on screw terminals or quick connectors. ● DIN-Rail mount. ● Connection to supervisory PC.

MS27: TECHNICAL DATA

Pressure input	type:	0/4...20mA
	range:	-1.0...45.0bar
	resolution:	0.1bar
	accuracy:	±0.2bar
Temperature input	type:	NTC10K
	range:	-50.0...120.0°C
	resolution:	0.5°C
	accuracy:	±0.5°C
Power supply	MS27...E	230Vac±10%, 50/60Hz, 3W
	MS27...U	115Vac±10%, 50/60Hz, 3W
Relay outputs	OUT1...OUT4	5(1)A
	Alarm	7(2)A
Front protection		IP55

APPLICATIONS:

for cryogenerators in supermarkets, cold stores and all cryogenic systems with variable demand.

MS27 series

	Functions	-1QE-B	-1SE-A	-1SU-B
Connections	Screw terminals		✓	✓
	Quick on M/F terminals	✓		
Power supply	230Vac	✓	✓	
	115Vac			✓
Serial port	TTL		✓	
	RS485	✓		✓

In order to know more options available for the models, please consult LAE or our local dealer.

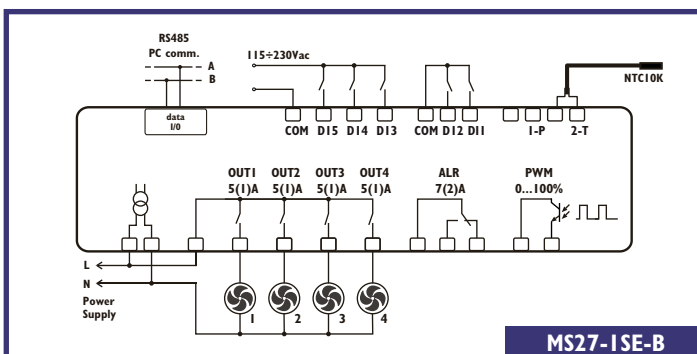
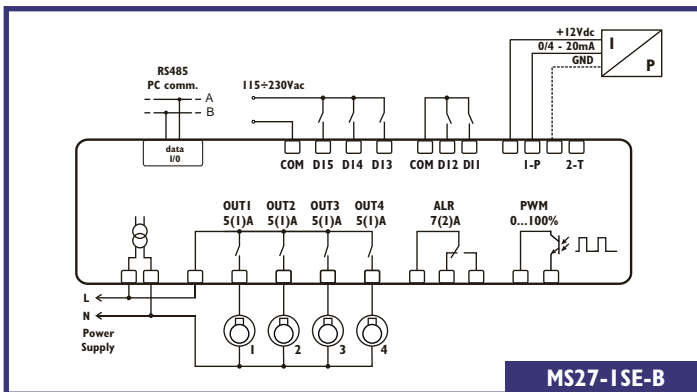
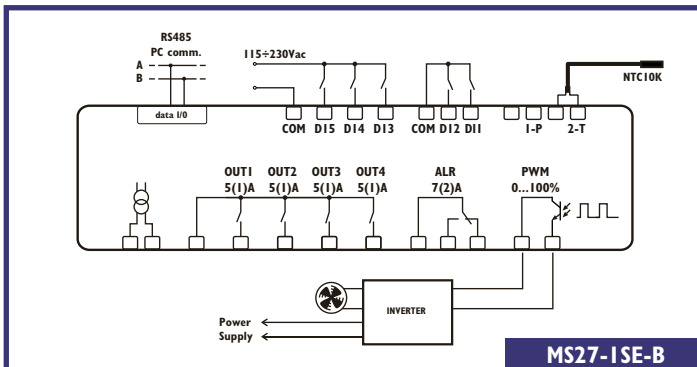

MTR6

64x32x81 mm

SINGLE OUTPUT THERMOSTAT

Panel controller with programmable differential ● Refrigerating or heating mode control selection ● Load start limitation ● Safety function in the event of breakage of the sensor ● Very compact size

APPLICATIONS:

Control of small cold stores, refrigerated cabinets and tables, heating systems, heated cupboards, bains-marie and ovens.



TECHNICAL DATA

Range:	50÷150°C
Resolution:	1°
Accuracy:	±0.7° (-30÷110°C)
Sensor type:	PTC; standard mod. ST1K20P1
Power supply:	12Vac/dc ±10%; 2W
Panel cut-out:	58x26 mm

Standard Versions	Front protection
MTR6T1RD	IP40
MTR6T1RDS	IP54

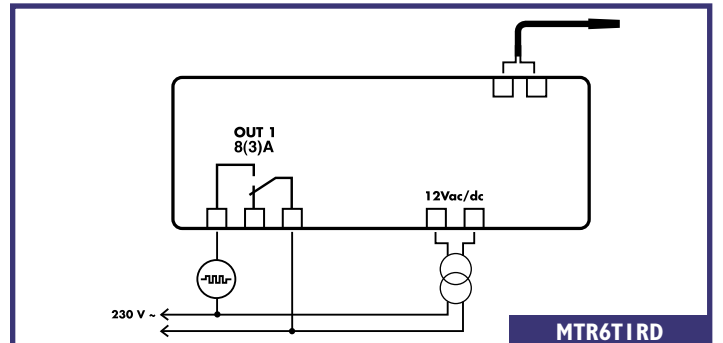

LLC1SE

LIQUID LEVEL CONTROLLER

Electrically detects the level of condensate in the drip tray of the refrigerator and activates the evaporation heaters.

APPLICATIONS:

This device completes the instruments that LAE provides for the control of professional refrigerators. For the evaporation of the water in the drip tray of the refrigerator.



TECHNICAL DATA

Dimensions:	91.5x54x55 DIN RAIL
Power supply:	230V ±10% 50/60 Hz
Consumption:	3W
Maximum load:	150W (resistive)
Timed operation:	3 minutes
Connections:	Screw terminals 2.5mm ²
Protection:	IP00

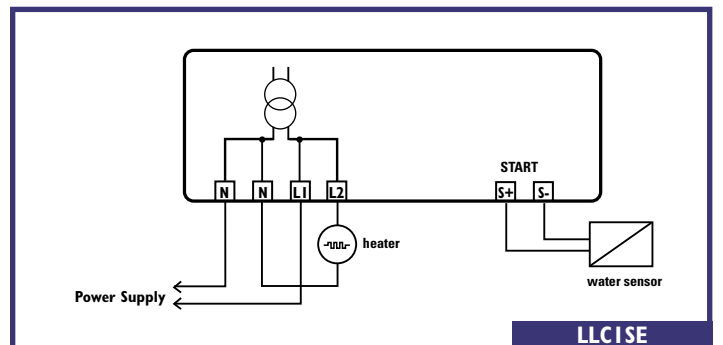



77x35x77 MM

LT12

WIDE RANGE THERMOMETER OR HYGROMETER

Panel display unit with range between -100 and $+900^{\circ}$ ● It's available in the version with $^{\circ}\text{C}$ or $^{\circ}\text{F}$ ● 0.1° or 1° resolution ● Input for PTC/Pt100/TC/0÷1V ● Runs on mains power supply.

APPLICATIONS:

Temperature: accurate measurements in cold stores, refrigerating cabinets and tables, greenhouses, seasoning cells, high temperature ovens or furnaces.

Humidity: accurate measurements in greenhouses, seasoning cells, air-conditioned rooms.

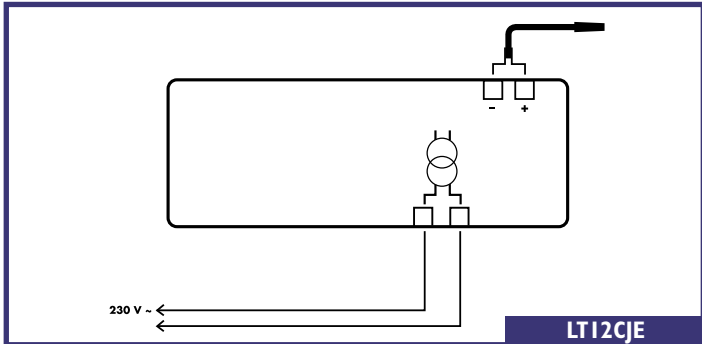

LT12CJE

LT12 Series : $^{\circ}\text{C}$ and %RH

Functions	CT D/I/E	CP D/I/E	CJ D/I/E	CK D/I/E	CA D/I/E
Input type	PTC*	Pt100	TC "J"	TC "K"	0÷1V
Range	$-50\div150^{\circ}\text{C}$	$-100\div600^{\circ}\text{C}$	$-50\div700^{\circ}\text{C}$	$-50\div900^{\circ}\text{C}$	$0\div100\%$ rH
Accuracy	S1**= $\pm 0.2^{\circ}\text{C}$; S2**= $\pm 1^{\circ}\text{C}$		$\pm 3^{\circ}\text{C}$		$\pm 0.1\%$
Resolution	S1**= 0.1°C ; S2**= 1°C		1°C		0.1%
Supply	..D= $12\text{Vac}/\text{dc}$; 2W /..I= $24\text{Vac}/\text{dc}$; 3W /..E= $230\text{Vac} \pm 10\%$; 50/60 Hz; 2W				
Protection	IP54				
Panel cut-out	71x29 mm				

* Standard PTC probe is STIK20P1

**Scale: S1 = $-19.9\div 99.9^{\circ}\text{C}$; S2 = remaining

Models with $^{\circ}\text{F}$ scale are also available.

In order to know versions available, please consult LAE or our local dealer.



77x35x77 MM

LTS12

CONFIGURABLE THERMOMETER OR HYGROMETER

Panel display unit ● Indicates the instant temperature or humidity and the min./max. measured values ● Easy selection of scale in $^{\circ}\text{C}/^{\circ}\text{F}$, of fixed or automatic resolution, input for PTC/Pt100, TC/J, 0...1V ● Runs on mains power supply

APPLICATIONS:

Temperature: measurements in cold stores, high temperature ovens or furnaces, washing machines and plants in which the thermometer requires configuration on the spot.

Humidity: measurements in greenhouses, seasoning cells, cold stores, air-conditioned rooms and plants in which the hygrometer requires configuration on the spot.

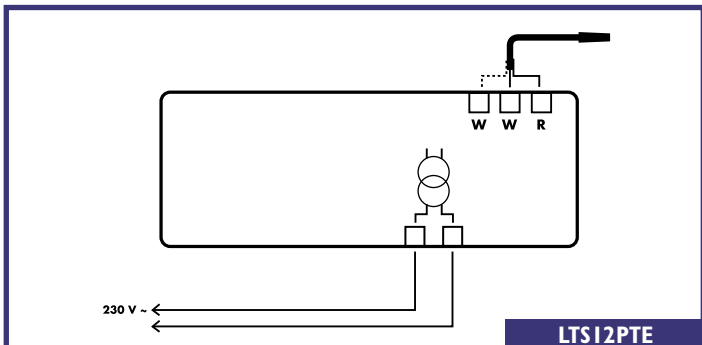

LTS12PTE

LTS12 Series

Functions	PT D/I/E	TC D/I/E	AV D/I/E
Input type	PTC*	Pt100	TC "J" TC "K"
Range	$-50\div150^{\circ}\text{C}$ $-60\div300^{\circ}\text{F}$	$-100\div600^{\circ}\text{C}$ $-150\div999^{\circ}\text{F}$	$-50\div700^{\circ}\text{C}$ $-60\div999^{\circ}\text{F}$ $-50\div900^{\circ}\text{C}$ $-60\div999^{\circ}\text{F}$
Accuracy	S1**= $\pm 0.2^{\circ}\text{C}$; S2**= $\pm 1^{\circ}\text{C}$ S1**= $\pm 0.4^{\circ}\text{F}$; S2**= $\pm 2^{\circ}\text{F}$		$\pm 3^{\circ}\text{C}$ $\pm 5^{\circ}\text{F}$ $\pm 0.1\%$
Resolution	S1**= 0.1°C ; S2**= 1°C 1°F		1°C 1°F 0.1%
Supply	..D= $12\text{Vac}/\text{dc} \pm 10\%$; 2W /..I= $24\text{Vac}/\text{dc} \pm 10\%$; 3W /..E= $230\text{Vac} \pm 10\%$; 50/60 Hz; 2W		
Protection	IP54		
Panel cut-out	71x29 mm		

*Standard PTC probe is STIN20P.

**Scale: S1 = $-19.9\div 99.9^{\circ}\text{C}$ / $0\div 212^{\circ}\text{F}$; S2 = remaining

In order to know versions available, please consult LAE or our local dealer.

TAB4.2

MONITORING, LOGGING AND PROGRAMMING SOFTWARE

Overall plant monitoring ● Compatible with the wireless communication system ● Storage of temperature, humidity, pressure, alarms ● Display and printing in numerical and graphic form of stored data ● Export of stored data for Excel* or others ● Diagnostics with dynamic graphs of all analog inputs ● Virtual instrument for analysing the system and setting regulator parameters ● Automatic sending or on demand of SMS to trace alarm status ● Connection to remote PC for tele-servicing via Internet ● Several languages available: English, German, Italian, Spanish, Polish etc.

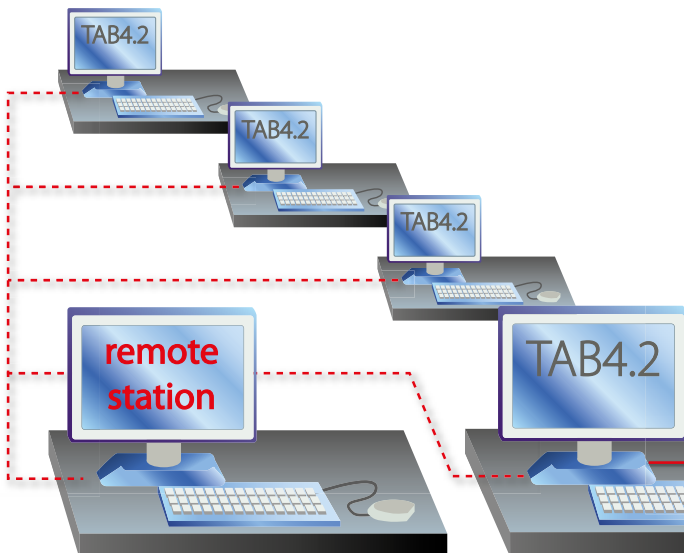

AVAILABLE OPTIONS

Available as full optional as described above but also in a "low cost version" for data logging only.

This version is called TAB4.2LV

APPLICATIONS

Supervision of the refrigeration process in supermarkets, convenience stores, shops, petrol stations, large kitchens, food factories, cruise ships etc.

- Computer with Windows XP/Vista/7* operating system installed and properly running, minimum processor and memory as required from Windows* version – USB port – Mouse – CD-ROM drive
- 1024x768 pixel screen resolution, 16-bit colour
- 1GB available on Hard Disk
- RS232 serial port (COM); an additional port is required if a GSM modem is fitted
- In case of wireless communication with the controllers, modules SWB-C and SWB-R are needed. Alternatively, an RS232-RS485 converter mod. SBC485 has to be fitted in case of a hard-wired system.
- GSM modem for sending SMS

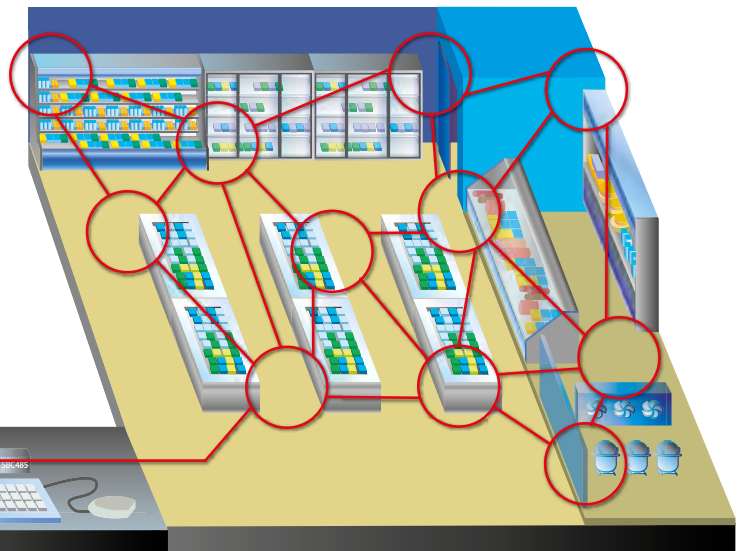

WIRELESS PLANT MONITORING



THE LAE ELECTRONIC WIRELESS COMMUNICATION SYSTEM, COMBINED WITH THE **TAB** SUPERVISORY SOFTWARE, ALLOWS EQUIPMENT RUN BY **LAE** CONTROLLERS TO BE MONITORED EASILY WITHOUT THE NEED OF A HARD-WIRED CABLE. THIS SYSTEM WILL BE PARTICULARLY USEFUL IN SUPERMARKETS AND KITCHENS WHERE THE LAYING OF WIRES IS COSTLY AND DIFFICULT, BOTH FOR NEW AND EXISTING UNITS.

THE **SWB** MODULES DEVELOPED BY **LAE** ELECTRONICS, ALLOW ALL THE **LAE** CONTROLLERS FITTED WITH A **TTL** OR **RS485** PORT TO BE INCORPORATED INTO SUCH A SYSTEM.

THE PLANT SUPERVISORY **PC**, RUNNING THE **TAB** SOFTWARE, IS CONNECTED VIA AN **SWB-C** VERSION OF THE MODULE ALLOWING COMMUNICATION TO ALL CONTROLLERS WITHIN THE WIRELESS NETWORK

THE CONTROLLERS USE THE **SWB-R** MODULE VERSION, SO THAT ONCE CONNECTED THEY WILL AUTOMATICALLY BECOME PART OF THE NETWORK.

EASY-TO-INSTALL AND POWERFUL

The radio communication protocol used, allows a "mesh" type wireless communication network to be created. This means that the data may reach even the furthest controller via **SWB-R** modules linked through the intermediate controllers. In this way, the actual creation of a network is greatly simplified. To add a controller to an existing network, you just have to ensure it is within 30-40m of an individual module. If there are no **SWB-R** modules within communications range, a stand-alone **SWB-R** can be powered up half way, to boost the signal and bridge the gap. This style of network can easily cover even vast areas with controllers separated by long distances.

SAFE AND RELIABLE

Once that the installation procedure has been performed successfully, the network consisting of **SWB** modules will automatically close the access to any other foreign wireless device which may work on the same radio channel. In this way no interference and intrusions of any type are possible and therefore data reliability and integrity are ensured.

FLEXIBLE

The **SWB** modules may be used to create a fully wireless network (a module for each controller); to connect segments of a cabled **RS485** line to the wireless network (more controllers with **RS485** port connected to an **SWB-R** module), or to add individual controllers to an existing network without laying additional cables.

SWB-R MODULE

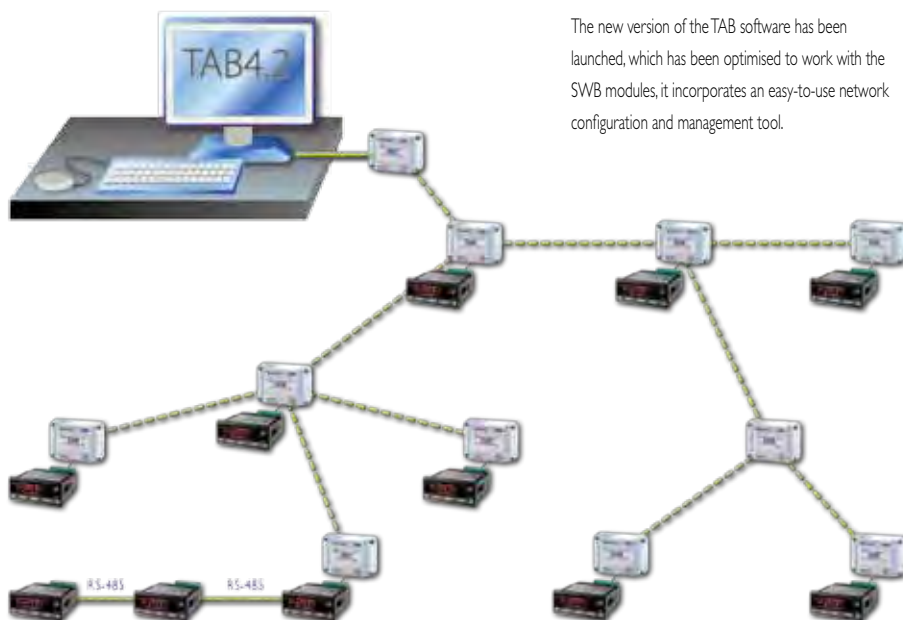

The new version of the **TAB** software has been launched, which has been optimised to work with the **SWB** modules, it incorporates an easy-to-use network configuration and management tool.

TECHNICAL SPECIFICATIONS OF SWB MODULES

- Radio frequency band: ISM 2.4GHz
- Range: up to 40m indoor with obstacles
- Serial port: **SWB-C**: RS232 on DB-9 connector
SWB-R: selectable TTL/RS485, on Ampmodu II 4-way connector
- Max. number of peripherals on RS485 port: 63
- LED's: power supply / associated to network, serial port transmission, serial port receive
- Power supply: 230Vac/3W
- Dimensions: 110x75x53 mm

COMPONENTS OF THE SYSTEM TO BE ORDERED

- **TAB4.2** software
- **SWB-C** module, PC side
- **SWB-R** modules (one for every controller or one for every "x" controllers wired with each other through the RS485 serial line)
- Connection cable from **SWB-C** module to a PC
- Connection cable from **SWB-R** module to a controller

WBS-01

WEB SERVER



THE **WBS-01** IS A COMPLETE AND INTEGRATED WEB-BASED SOLUTION FOR REMOTE MONITORING, DATA LOGGING AND ALARM MANAGEMENT IN PLANTS WHERE **LAE** ELECTRONIC CONTROLLERS ARE FITTED.

THE INCORPORATED WEB SERVER GRANTS ACCESS TO THE MEASURED VALUES, TO THE CONFIGURATION PARAMETERS OF CONTROLLERS, TO THE ALARM STATES, TO RECORDED DATA AND TO CONFIGURATION OF THE **WS100** THROUGH AN ORDINARY BROWSER.

VARIOUS USERS MAY BE ENABLED TO GET ACCESS TO THE SYSTEM WITH DIFFERENT RIGHTS AND EACH OF THEM CAN RECEIVE RECORDED DATA AND ALARM MESSAGES TO HIS/HER E-MAIL ADDRESS.

CONFIGURATION IS EXTREMELY EASY AND QUICK TO MAKE THANKS TO THE TEMPLATES FOR VARIOUS CONTROLLERS THAT **LAE** MAKES AVAILABLE AND THANKS TO THE AUTOMATIC DETECTION OF THE CONNECTED DEVICES.

IN THE EVENT THAT AN INTERNET ACCESS IS NOT AVAILABLE, REMOTE CONNECTION MAY TAKE PLACE EVEN THROUGH **GSM/GPRS** WITH THE ADDITION OF AN EXTERNAL MODEM, WHICH WILL ALSO SEND OUT **SMS** MESSAGES.

FURTHERMORE, IT'S POSSIBLE TO USE THE ONLINE NETBITER.NET PORTAL OFFERING DATA COLLECTION AND STORAGE, GRAPH REPRESENTATION, PARAMETER PROGRAMMING AND ALARM MANAGEMENT SERVICES AND IT MAKES THESE FUNCTIONS AVAILABLE THROUGH A SIMPLE LINK TO JUST ONE WEBSITE.

IN THIS WAY THERE WILL BE NO NEED FOR A STATIC IP ADDRESS,

A FIREWALL CONFIGURATION MODIFICATION OR THE USE OF A SPECIFIC **SIM** CARD FOR **GSM/GPRS** CONNECTION, MOREOVER A CENTRALIZED MANAGEMENT OF MORE PLANTS WILL TURN OUT TO BE EASIER.

MAIN FEATURES

- Built-in web server for accessing device data and configuration
- Data logger with graph representation and data export in text format
- Alarm management with list of current events, list of stored events, e-mail or SMS sending
- Management of several users with different access rights and alarm messages reception
- Simplified configuration through templates of **LAE** controllers and automatic detection of the connected devices
- Communication ability in absence of Internet line and SMS sending by connecting an external analog or **GSM/GPRS** modem
- Ability to get access to data through Internet portal
- 2 digital inputs that may be monitored and controlled as external alarm sources.

TECHNICAL DATA

Ethernet port:	10/100 Mbit/s, RJ45 connector
Serial port #1:	RS-485, screw terminal
Serial port #2:	RS-232 DSUB 9-pin connector
Power supply:	9÷24V AC/DC 2W
Operating temperature:	-40÷65°C
Housing:	DIN rail, 4 modules, 90x70x58mm
Certification:	EN 61000-6-2:2005 and 61000-6-4:2001, UL 508

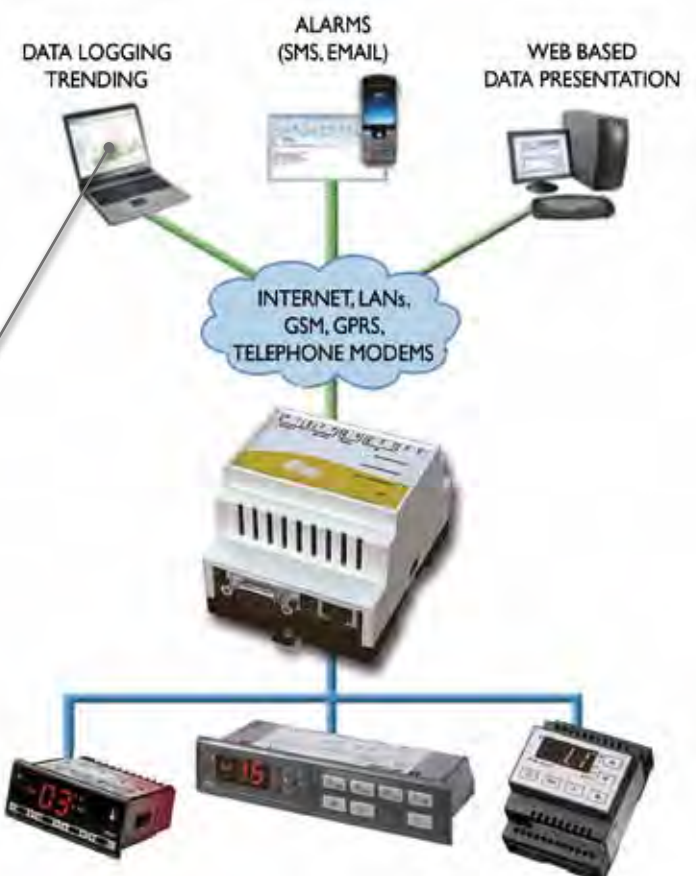

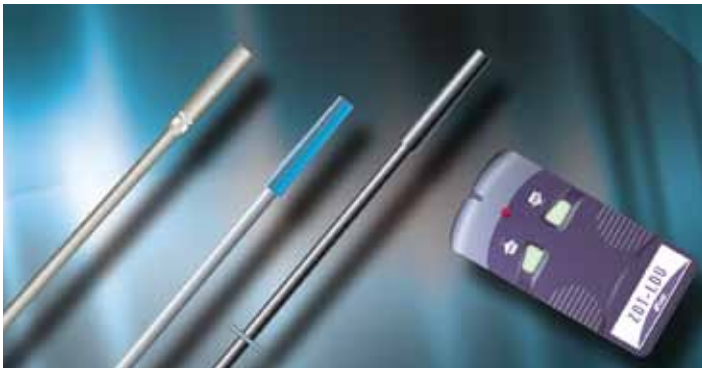

PROGRAMMING KEY

ZOT - ZERO OPERATOR'S TIME

Ergonomic device for easy end-of-the-line controller configuration ● Permanent memory of stored setup values ● Can communicate with TTL and RS485 ports ● Requires no battery

TECHNICAL DATA

Communication port:	TTL and RS485
Connection:	4-pin connector
Power supply:	from the connected instrument
Consumption:	0.2W (5Vdc)
Front Protection:	IP20
Dimensions:	41x20x88 mm



TEMPERATURE PROBES

SN2B..P

Sensor type:	NTC2K, 2000Ω @ 25°C
Range:	-40÷120°C
Accuracy:	±0.3°C @ 25°C
Sheath:	Ø6x29mm; TPE
Cable:	2 wires x 0.35mm ² ; -40÷120°C; TPE; points
Protection:	IP67

SN4B..P

Sensor type:	NTC10K, 10000Ω @ 25°C
Range:	-40÷120°C
Accuracy:	±0.3°C @ 25°C
Sheath:	Ø6x29mm; TPE
Cable:	2 wires x 0.35mm ² ; -40÷120°C; TPE; points
Protection:	IP67

STIK..C/P

Sensor type:	KTY81-121, 990Ω @ 25°C
Range:	-40÷105°C
Accuracy:	±1.5°C @ 25°C
Sheath:	Ø6x34mm; TPE
Cable:	2 wires x 0.35mm ² ; -40÷105°C; TPE; connector or points
Protection:	IP67

STIN..P-

Sensor type:	KTY81-121, 990Ω @ 25°C
Range:	-40÷110°C
Accuracy:	±1.5°C @ 25°C
Sheath:	Ø7x40mm; nylon6
Cable:	3 wires x 0.22mm ² ; screen; -40÷110°C; PETE; points
Protection:	IP67

HUMIDITY TRANSMITTERS

HT2WAD

Sensor type:	Capacitive
Output signal:	0÷1Vdc
Range:	0%÷100%r.H
Accuracy:	±5%r.H. (25%÷75%r.H.)
Sheath:	Ø14x40mm
Protection:	IP65 (electronics)
Operating temperature:	0÷75°C (sensor) / 0÷50°C (electronics)
Dimensions of the enclosure:	110x53x75mm (electronics)
Power supply:	12Vdc, 0.2W

HUMIDITY AND TEMPERATURE TRANSMITTER

HT2WSE

Sensor type:	Capacitive
Output signal:	RS485
Range:	0%÷100%r.H / 0÷70°C
Accuracy:	±5%r.H. (25%÷75%r.H.) / ±0.3°C @ 25°C; ±1°C (0÷70°C)
Sheath:	Ø14x40mm
Protection:	IP65 (electronics)
Operating temperature:	0÷75°C (sensor) / 0÷50°C (electronics)
Dimensions of the enclosure:	110x53x75mm (electronics)
Power supply:	12Vdc, 0.2W

PRESSURE TRANSMITTER

PGT35

Sensor type:	Piezoresistive gauge
Output:	4÷20mA
Range:	-0,5÷35,0 bar
Accuracy:	max±1%FS (0÷50°C)
Sheath:	Ø17x58 mm
Connections:	mPm connector
Pressure port:	7/16"-20UNF male, steel AISI 316L
Protection:	IP65
Ambient temperature:	-40÷100°C
Power supply:	8÷32Vdc



S-28-FB

FIXING BAR FOR 28 SERIES



SBC485

CONVERTER

To be used in conjunction with TAB software in case of hard-wired system - RS232 to RS485 interface between PC and connected controllers.

TECHNICAL DATA

Dimensions	110x75x53 mm (WxHxD)
Ambient temperature	0...+50°C
RS232 connection	DB9 female connector
RS485 connection	8-pole RJ45 connector
Maximum load	63 peripherals+ 120ohm termination
Connection length	1.2Km
Power supply	115V or 230Vac
Consumption	3W
Front protection	IP20



Transformers

Code	Voltage of primary	Voltage of secondary	Frequency	Power	Dimensions (WxHxD mm)	Overtemp. protection	Approvals
TR230	230Vac	12Vac/dc	50/60 Hz.	3VA	60.5x48x36		ENEC
TR230F	230Vac	12Vac/dc	50/60 Hz.	3VA	60.5x48x36	✓	ENEC
TR240	240Vac	12Vac/dc	50/60 Hz.	3VA	60.5x48x36		ENEC
TR110	110Vac	12Vac/dc	50/60 Hz.	3VA	60.5x48x36		
TR115	115Vac	12Vac/dc	50/60 Hz.	3VA	60.5x48x36		UL
TR24/12V	24Vac	12Vac/dc	50/60 Hz.	3VA	60.5x48x36		

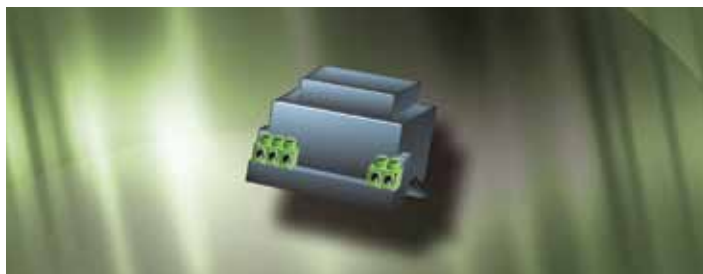

first-class ideas



Monitoring, Logging and Programming Software

Wireless plant monitoring



Teleservicing



maximum adaptability

Complexity simplified

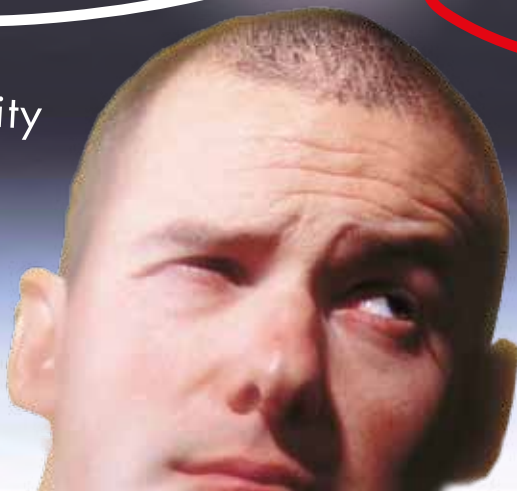

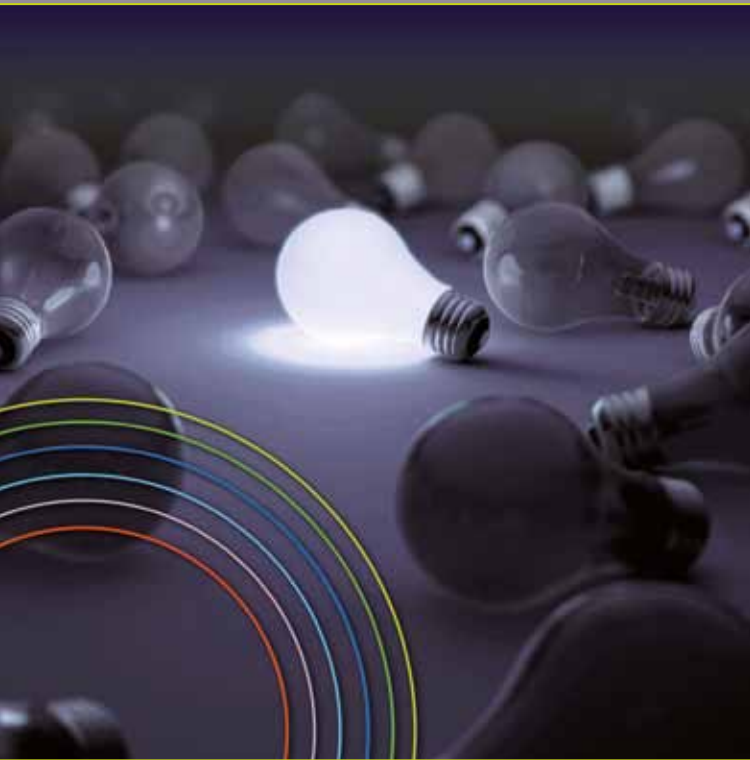

LOTS OF OPTIONS, JUST ONE CHOICE.

По вопросам продаж и поддержки обращайтесь:

Архангельск (8182)63-90-72
Астана (7172)727-132
Астрахань (8512)99-46-04
Барнаул (3852)73-04-60
Белгород (4722)40-23-64
Брянск (4832)59-03-52
Владивосток (423)249-28-31
Волгоград (844)278-03-48
Вологда (8172)26-41-59
Воронеж (473)204-51-73
Екатеринбург (343)384-55-89

Иваново (4932)77-34-06
Ижевск (3412)26-03-58
Казань (843)206-01-48
Калининград (4012)72-03-81
Калуга (4842)92-23-67
Кемерово (3842)65-04-62
Киров (8332)68-02-04
Краснодар (861)203-40-90
Красноярск (391)204-63-61
Курск (4712)77-13-04
Липецк (4742)52-20-81

Магнитогорск (3519)55-03-13
Москва (495)268-04-70
Мурманск (8152)59-64-93
Набережные Челны (8552)20-53-41
Нижний Новгород (831)429-08-12
Новокузнецк (3843)20-46-81
Новосибирск (383)227-86-73
Омск (3812)21-46-40
Орел (4862)44-53-42
Оренбург (3532)37-68-04
Пенза (8412)22-31-16

Пермь (342)205-81-47
Ростов-на-Дону (863)308-18-15
Рязань (4912)46-61-64
Самара (846)206-03-16
Санкт-Петербург (812)309-46-40
Саратов (845)249-38-78
Севастополь (8692)22-31-93
Симферополь (3652)67-13-56
Смоленск (4812)29-41-54
Сочи (862)225-72-31
Ставрополь (8652)20-65-13

Сургут (3462)77-98-35
Тверь (4822)63-31-35
Томск (3822)98-41-53
Тула (4872)74-02-29
Тюмень (3452)66-21-18
Ульяновск (8422)24-23-59
Уфа (347)229-48-12
Хабаровск (4212)92-98-04
Челябинск (351)202-03-61
Череповец (8202)49-02-64
Ярославль (4852)69-52-93

www.lae.nt-rt.ru || ecr@nt-rt.ru